

Interior Solutions



BRANDING 101

Branding - 101

- A. Branding is one of the most important aspects of any business.
- B. Branding identifies you to your customers using logos, specific color themes, tag lines, and graphics, differentiating your business from your competitors.
- C. Branding extends to every aspect of your business-- from how you answer your phones, to what you or your sales people wear, to how clean your restrooms are. Great branding includes everything.
- D. Branding done right will instill a confidence of quality in your customers that leads to customer loyalty which in turn drives up revenues. It becomes a win for both you and your customers.

- As markets evolve and become more competitive, it is becoming increasingly important for organizations to focus on their brand identity.

INDEX

Branding 101 -----	page 2.
Layout Examples -----	page 4.
Price Guide -----	page 8.
Branded Elements -----	page 11.
Individual Elements -----	page 21.
Graphics -----	page 46.
Seating -----	page 57.
Floors & Paint -----	page 69.
Where to Purchase -----	page 70.
How-To Guide -----	page 71.
Restroom Etiquette -----	page 76.



*“Your brand is created out of customer contact
and the experience your customers have.”*

- Stelios Haji-Ioannou

LAYOUT EXAMPLES

SMALL

Layout - 15 ft. x 15 ft. or Less

Estimated Price Range \$9,500 - \$14,500

- Lower price estimate includes furniture and seating with painted walls. Lower estimated price excludes wall coverings, blue display panels, fabric graphics, & flooring.
- Higher price estimate includes all elements shown in floor plan.



MEDIUM

Layout - 15 x 15 ft. to 25 x 25 ft.

Estimated Price Range \$11,000 - \$16,500

- Lower price estimate includes furniture & seating with painted walls. Lower estimated price excludes wall coverings, blue display panels, fabric graphics, and flooring.
- Higher price estimate includes all elements shown in floor plan.



LARGE

Layout - 25 x 25 ft. or Larger

Estimated Price Range \$19,000 - \$29,500

- Lower price estimate includes furniture & seating with painted walls. Lower estimated price excludes wall coverings, blue display panels, fabric graphics, & flooring.
- Higher price estimate includes all elements shown in floor plan.



*Prices shown are estimates and subject to change depending upon facility size and location.

*Shipping and Tax not included and vary by location.



SMALL Layout - 15 x 15 ft. or Less

Price Range \$9,500 - \$14,500

- Lower price estimate includes furniture and seating with painted walls. Lower estimated price excludes wall coverings, blue display panels, fabric graphics, and flooring.

- Higher price estimate includes all elements shown in floor plan.



*Prices shown are estimates and are subject to change depending upon facility size and location.

*Shipping and Tax not included and vary by location.



MEDIUM Layout - 15 x 15 ft. - 25 x 25 ft.



Price Range \$11,000 - \$16,500

- Lower price estimate includes furniture and seating with painted walls in floor plan above. Lower estimated price excludes wall coverings, blue display panels, fabric graphics, & flooring.
- Higher price estimate includes all elements shown in floor plan above.



*Prices shown are estimates and are subject to change depending upon facility size and location.
 *Shipping and Tax not included and vary by location.





LARGE Layout - 25 x 25 ft. or Larger

Price Range
\$19,000 - \$29,500

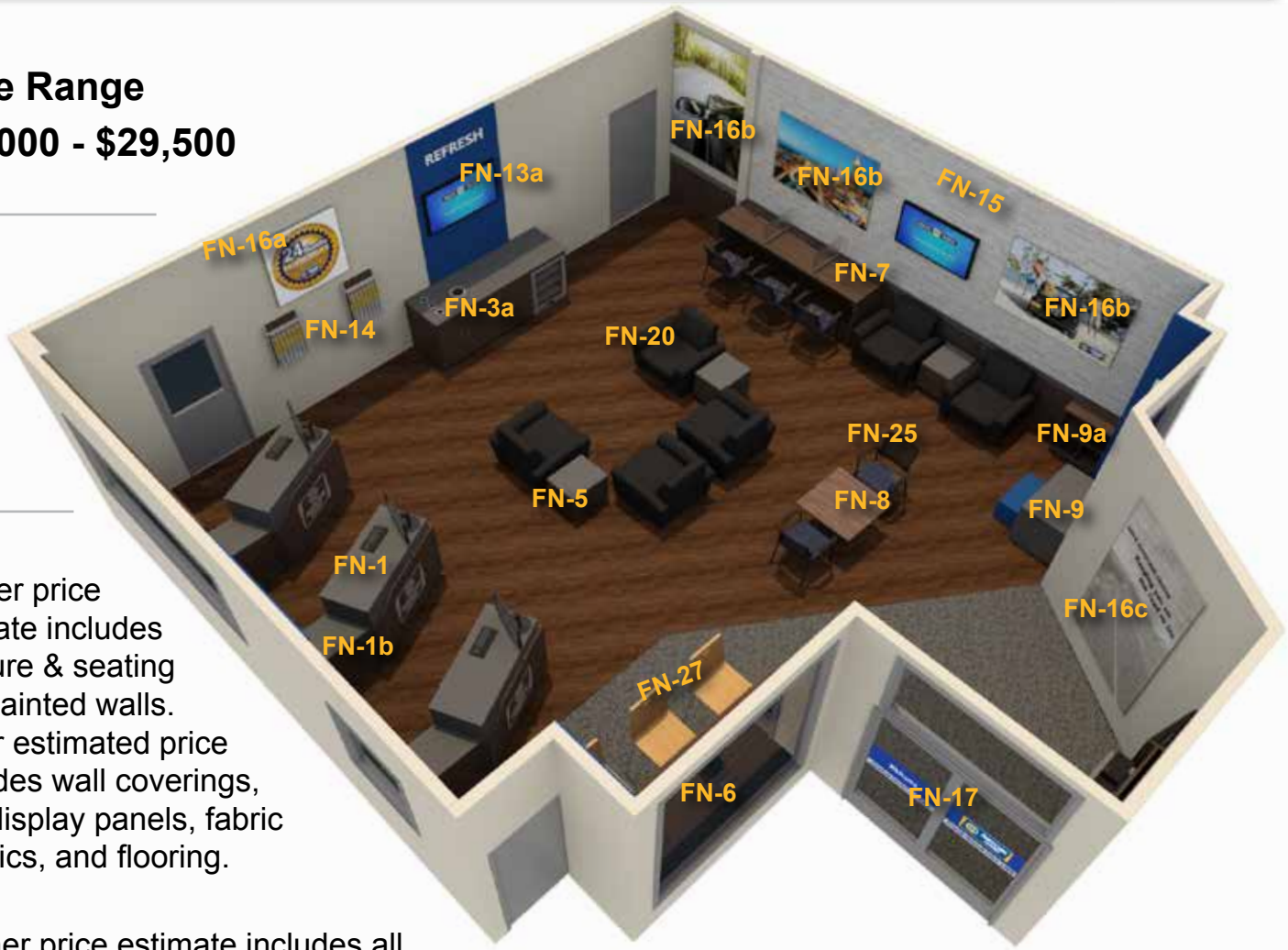

- Lower price estimate includes furniture & seating with painted walls. Lower estimated price excludes wall coverings, blue display panels, fabric graphics, and flooring.















- Higher price estimate includes all the elements shown in floor plan.



















*Prices shown are estimates and are subject to change depending upon facility size and location.
 *Shipping and Tax not included and vary by location.







PRICE GUIDE

	FN-1	Service Desk, Finish in laminate with Box,Box,File and Open Cabinet	\$ 1,394.00	\$ -
	FN-1A	Optional Printer/ ADA Cabinet as Straight Return	\$ 347.00	\$ -
	FN-1B	Optional Printer/ ADA Cabinet as Angled Return	\$ 397.00	\$ -
		Stainless Steel Napa Logos	\$ 431.00	\$ -
	FN-2	Service Desk Back Counter- Large, includes (2) Storage Cabinets or Lateral File Cabinets	\$ 1,361.00	\$ -
	FN-2A	Service Desk Back Counter- small- finished in laminate with (1) Storage Cabinet or Lateral File Cabinet	\$ 1,149.00	\$ -
	FN-3	Café Unit with (1) Storage Cabinet and Refrigerator opening with trash ring.	\$ 855.00	\$ -
		<u>Optional Accessories for Café:</u>		
		Refrigerator	\$ 1,075.00	\$ -
		Condiment Holders (Qty. 3)	\$ 72.00	\$ -
	FN-3A	Large Café, finished in Laminate with (2) Storage Cabinets, Refrigerater Opening and trash ring.	\$ 1,331.00	\$ -
		<u>Optional Accessories for Café:</u>		
		Refrigerator	\$ 1,075.00	\$ -
		Condiment Holders (Qty. 3)	\$ 72.00	\$ -
	FN-4	Tall Café, finished in Laminate with (1) Storage Cabinet, Upper Cabinet and trash ring.	\$ 993.00	\$ -
	FN-5	Lounge End Table- finished in Laminate with power grommet.	\$333.00	\$ -
	FN-6	Café Bar Freestanding- finished in Laminate with (3) power grommets.	\$761.00	\$ -
		Optional Magazine Holders for Café Bar (set of 2)	\$70.00	\$ -
		Optional iPad Stands for Café Bar	\$180.00	\$ -
	FN-7	Business Center- finished in Laminate with (3) power grommets.	\$ 761.00	\$ -
		Optional Divider Panels with hardware- set of 2	\$ 183.00	\$ -
	FN-8	Café Table finished in Laminate with black cast iron leg- 30" x 30" x 30" t	\$ 416.00	\$ -
	FN-8a	Café Table finished in Laminate with black cast iron leg- 20" x 20" x 42" t	\$ 416.00	\$ -
	FN-9	Kids Play Area Table/ (2) Blue Laminate Stools	\$ 495.00	\$ -

PRICE GUIDE

	FN-9A	Kids Play Area- Cubbies		\$ 322.00	\$ -
	FN-10	Battery Display- Finished in Laminate. Includes (2) Shelves and tire bracket Graphic blades by others		\$ 1,013.00	\$ -
	FN-11	Certification Panel- finished in laminate. Certification Plaques by others		\$ 192.00	\$ -
	FN-12	Laminate Wainscoating with 4" chair rail- price per ln. ft.- height is 40" t		\$ 26.44	\$ -
	FN-13A	Blue Panel with REFRESH- 6" T Acrylic Lettering		\$ 610.00	\$ -
	FN-13B	Blue Panel with PLAY- 6" T Acrylic Lettering		\$ 594.00	\$ -
	FN-13C	Blue Panel with SERVICE- 6" T Acrylic Lettering		\$ 610.00	\$ -
	FN-13D	Blue Panel with CHARGE- 6" T Acrylic Lettering		\$ 610.00	\$ -
	FN-14	Wiper Display		\$ 418.00	\$ -
	FN-15	Wallpaper Image with slogans- per linear ft.		\$ 77.40	\$ -
	FN-16a	3' x 3' "Warranty" Fabric Graphic		\$ 246.00	\$ -
		Optional Image: Selection		Check Box Below	
		"24 Month Warranty" Fabric Graphic			\$ -
		"36 Month Warranty" Fabric Graphic			\$ -
	FN-16b	4' x 3' Fabric Graphic - see Graphic Deck for Image Selection.		\$ 263.00	\$ -
	FN-16c	4' x 7' Map Graphic - see Catalog for regional image options		\$ 555.00	\$ -
	FN-17	Welcome Door Welcome Clings		\$ 251.00	\$ -
	FN-18	"Signage Package:"			
	FN-18a	Room Identification Signs		\$ 87.00	\$ -
	FN-18b	ADA Restroom Sign		\$ 140.00	\$ -
	FN-18c	Promotional Table Stand Sign		\$ 111.00	\$ -

PRICE GUIDE

	FN-18d	Table Stand Sign		\$ 60.00	\$ -
	FN-18e	Flag Mount Wayfinding Sign		\$ 145.00	\$ -
	FN-19	Cork Board with Logo		\$ 109.00	\$ -
	FN-20	Reception Chair - Option 1		\$ 437.76	\$ -
	FN-21	Reception Chair - Option 2		\$ 460.22	\$ -
	FN-22	Reception Arm Chair		\$ 358.70	\$ -
	FN-23	Guest Chair - Option 1		\$ 152.64	\$ -
	FN-24	Guest Chair - Option 2		\$ 88.00	\$ -
	FN-25	Guest Chair - Option 3		\$ 213.12	\$ -
	FN-26	Café Chair		\$ 156.96	\$ -
	FN-27	Bar Stool		\$ 206.78	\$ -
	FN-28	High Back Chair		\$ 265.00	\$ -
	FN-29	Mesh Guest Chair		\$ 172.22	\$ -
	FN-30	Armless Guest Chair		\$ 71.12	\$ -
	FN-31	Arms Guest Chair		\$ 80.08	\$ -

Branded Elements



FN-1 Service Desk

Finish in laminate with Box, Box File, Open Cabinet, and CPU Holder. *CPU, Monitor, and Keyboard not included.

Approx. Dim. 4' 2 5/8" W x 1' 11 1/8" D x 3' 7" H



Option NAPA Logo

Optional 1/8 inch Stainless Steel Napa Logo.

ADA Dim. 20" W x 15 3/4" T



FN-1a ADA Extension - Straight

ADA Extension finished in laminate with Printer Storage/Cabinet.

ADA Dim. 2' 6" W x 1' 8" D x 2' 6" H



FN-1b ADA Extension - Angled

ADA Extension finished in laminate with Printer Storage/Cabinet.

ADA Dim. 3' 0" W x 1' 8" D x 2' 6" H



FN-2 Service Desk Back Counter Large

Finished in laminate, includes (2) two door storage cabinets.

*Two drawer lateral file cabinet available upon request.

Approx. Dim. 5' 4" W x 2' 2 1/2" D x 2' 9 3/4" H

Branded Elements



FN-2a Service Desk Back Counter Small

Finished in laminate with (1) two door storage cabinet.
**Drawer lateral file cabinet available upon request.*

Approx. Dim. 2' 8" W x 2' 2 1/2" D x 2' 9 3/4" H



FN-3 Cafe

Finished in Laminate w/ (1) Storage Cabinet, Trash Ring, and Refrigerator Opening. **Shown w/ Optional Condiment holders and Refrigerator.*

Approx. Dim. 4' 10" W x 2' 2 1/2" D x 2' 9 3/4" H



FN-3a Large Cafe

Finished in Laminate w/ (2) Storage Cabinets, Trash Ring, and Refrigerator Opening. **Shown w/ Optional Condiment holders and Refrigerator.*

Approx. Dim. 7' 6" W x 2' 2 1/2" D x 2' 9 3/4" H



Option Refrigerator

Under counter Refrigerator with glass door and metal trim for FN-3 Cafe or FN-3a Large Cafe.

Approx. Dim. 23.63" W x 23.5" D x 32.38" H



Option Condiment Holders

Optional Condiment holder accessory for Cafe.

Approx. Dim. 5" Dia. x 6.5" H

Branded Elements



FN-4 Tall Cafe

Finished in Laminate w/ (1) Storage Cabinet, Trash Ring and upper storage. **Shown w/ Optional Condiment holders.*

Approx. Dim. 2' 8" W x 2' 0" D x 7' 5 7/8" H



FN-5 Lounge End Table

Lounge end table finished in Laminate w/ power Grommet.

Approx. Dim. 1' 3" W x 1' 3" D x 1' 6" H



FN-6 Cafe Bar

Freestanding bar- finished in Laminate with power grommets.

**Shown with optional Magazine Holders.*

Approx. Dim. 7' 10" W x 2' 0" D x 3' 5 1/2" H



Option Magazine Holders

Set of (2) Magazine holders for Cafe Bar.

Approx. Dim. 17.5" W x 3" D x 12" H



Option iPad Stands

Optional iPad Stands for Cafe Bar.

Approx. Dim. 10.8" W x 4" D x 8.1" H



Branded Elements



FN-7 Business Bar

Business Center- finished in Laminate with power grommets.

**Shown with optional set of Divider Panels.*

Approx. Dim. 7' 0" W x 2' 0" D x 2' 6" H



Option Divider Panels

Optional Divider Panels with hardware- set of 2.

Approx. Dim. 1' 10" W x 1' 0" H



FN-8 Cafe Table

Café Table finished in Laminate with black cast iron leg.

Approx. Dim. 30" W x 30" D x 30" H



FN-8a Cafe Table

Café Table finished in Laminate with black cast iron leg.

Approx. Dim. 20" W x 20" D x 42" H



FN-9 Kids Play Table w/ (2) Stools

Play Table w/ (2) Blue Laminate Stools.

Approx. Table Dim. 3' 0" W x 2' 0" D x 2' 0" H

Approx. Stool Dim. 2' 0" W x 1' 0" D x 1' 0" H



Branded Elements



FN-9a Kids Play Area- Cubby

Kids Play Area- Cubby.

Approx. Dim. 2' 2 1/4" W x 1' 0" D x 2' 4" H



FN-10 Premium Battery / Tire Display

Battery Display- Finished in Laminate. Includes (2) Shelves, (1) tire bracket, and (2) Graphic Frames. *Batteries, Wheel, and Graphics not included.

Approx. Dim. 5' 8 1/2" W x 1' 7 7/8" D x 5' 6" H



FN-11 Certification Panel

Finished in laminate. *Certification Plaques by others.

Approx. Dim. 7' 1/8" W x 2' 5 7/8" H



FN-12 Laminate Wainscoting & 4" Chair Rail

Laminate Wainscoting with 4" chair rail and 4" base trim- price per ln. ft.

Approx. Dim. 32" W sections x 34.75" T

REFRESH

FN-13a REFRESH Wallpaneling

Blue Wallpaneling w/ 6" White "REFRESH" Lettering.

Approx. Dim. 3' 4" W x 1.5 D x 7' 10" H

Branded Elements

PLAY

FN-13b Kids Play Area Wallpaneling
Blue Wallpaneling w/ 6" White "PLAY" Lettering.
Approx. Dim. 3' 4" W x 1.5 D x 7' 10" H

SERVICE

FN-13c Blue Service Display Panel
Blue Display Panel w/ 6" White "SERVICE" Lettering.
Approx. Dim. 3' 4" W x 1.5 D x 7' 10" H

CHARGE

FN-13d Blue Charge Display Panel
Blue Display Panel w/ 6" White "CHARGE" Lettering.
Approx. Dim. 3' 4" W x 1.5 D x 7' 10" H



FN-14 Windshield Wiper Display
Premium Windshield wiper display.
Approx. Dim. 1' 2" W x 2' H



FN-15 Graphic Wall Words
Wallpaper Image with destination words - per linear ft. Wallpaper will always be above Wainscoating. Custom sizing for floor to ceiling available upon request.
Approx. Dim. Varies

"7 in 10 Americans said they were willing to spend more with companies they believe provide excellent customer service." – American Express Survey



Branded Elements



FN-16a Fabric Warranty Graphic
Fabric Graphic - 24 months or 36 Months.
Approx. Dim. 3' W x 3' T



FN-16b Fabric Graphic
Premium Fabric Graphic.
Approx. Dim. 4' W x 3' T



FN-16c Map Graphic
Graphic image with map and "Keeping you on the road to life" slogan.
Approx. Dim. 4' W x 7' T

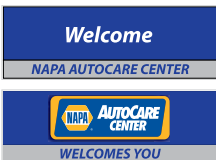

FN-17 Welcome Door Window Clings
Welcome door sign and Store hours window clings.
Approx. Dim. 36" W x 12" H



FN-18a Room Identification Signs
Acrylic Signs with Custom back-printed design in a dark gray color palette with beige raised, tactile lettering and #2 Braille.
Approx. Dim. 8" W x 4" H

Branded Elements



FN-18b ADA Restroom Sign

Acrylic Sign with Custom back-printed design in a dark gray color palette with beige, raised tactile lettering and #2 Braille.
Approx. Dim. 6.5" W x 9" H



FN-18c Promotional Table Stand Sign

Bent Acrylic Promotional Sign Stand. **Promotional inserts by others.*
Approx. Dim. 5.5" W x 8.5" H



FN-18d Table Stand Sign

Bent Acrylic Sign stand with Custom back-printed design in a dark gray color palette with beige, raised tactile lettering.
Approx. Dim. 6.25" W x 2.75" H



FN-18e Flag Mount Wayfinding Sign

Acrylic Signs with Custom back-printed design in a dark gray color palette with beige, raised tactile lettering.
Approx. Dim. 10" W x 6" H



FN-19 Corkboard

Corkboard with NAPA logo design burned into the corkboard.
Approx. Dim. 24" W x 36" H

"A 5% increase in customer retention increases profits up to 125%"

– Bain & Company

Branded Elements



FN-20 Reception Chair, Option 1
LLR68952 Black Leather Chair with Four Leg Base
Finished in Mahogany.
Approx. Dim. 36" W x 34.5" D x 31.3" H



FN-21 Reception Chair, Option 2
LLR68953 Black Leather Chair with Writing tablet and four
Leg Base finished in Mahogany.
Approx. Dim. 36" W x 34.5" D x 31.3" H



FN-22 Reception Arm-Chair
OSPWST51AB18 Black Faux Leather chair with Chrome base.
Approx. Dim. 30" W x 28" D x 30" H



FN-23 Guest Chair, Option 1
LLR40201 Guest Chair with Bonded Black Leather and
Solid Wood Espresso Frame.
Approx. Dim. 24" W x 25.6" D x 33.3" H



FN-24 Guest Chair, Option 2
LLR84577 Black Leather Chair with Black Metal Powder-
Coated Frame.
Approx. Dim. 26" W x 24.8' D x 33.5" H



FN-25 Guest Chair, Option 3
LLR2310010 Guest Chair with Mesh Back, Fabric Periwinkle
Blue Seat, and Black Powder-coated Steel Frame.
Approx. Dim. 23" W x 29" D x 32" H

Branded Elements



FN-26 Cafe Chair

LLR99864 Café Chair Natural plywood waterfall style seat with steel frame.

Approx. Dim. 21" W x 20.5" D x 34" H



FN-27 Bar Stool

LLR99866 High Bar Seating, Natural plywood waterfall style seat with steel frame.

Approx. Dim. 21.8" W x 20.5" D x 46" H



FN-28 High-back Chair

LLR59529 Black Leather High-back chair with height adjustable arms.

Approx. Dim. 25.3" W x 23.3" D x 40.5" H



FN-29 Mesh Guest Chair

LLR86202 Black Chair with side arms, Mesh back, Fabric seat, and Cantilever base.

Approx. Dim. 27" W x 27.8" D x 41" H



FN-30 Armless Guest Chair

BSXVL606VA90 Navy Blue Polyester Fabric with Black tubular steel frame.

Approx. Dim. 21.5" W x 21" D x 32.8" H



FN-31 Arms Guest Chair

BSXVL616VA90 Guest Chair with arms, Navy Blue Polyester Fabric with Black tubular steel frame.

Approx. Dim. 23.3" W x 21" D x 32.8" H

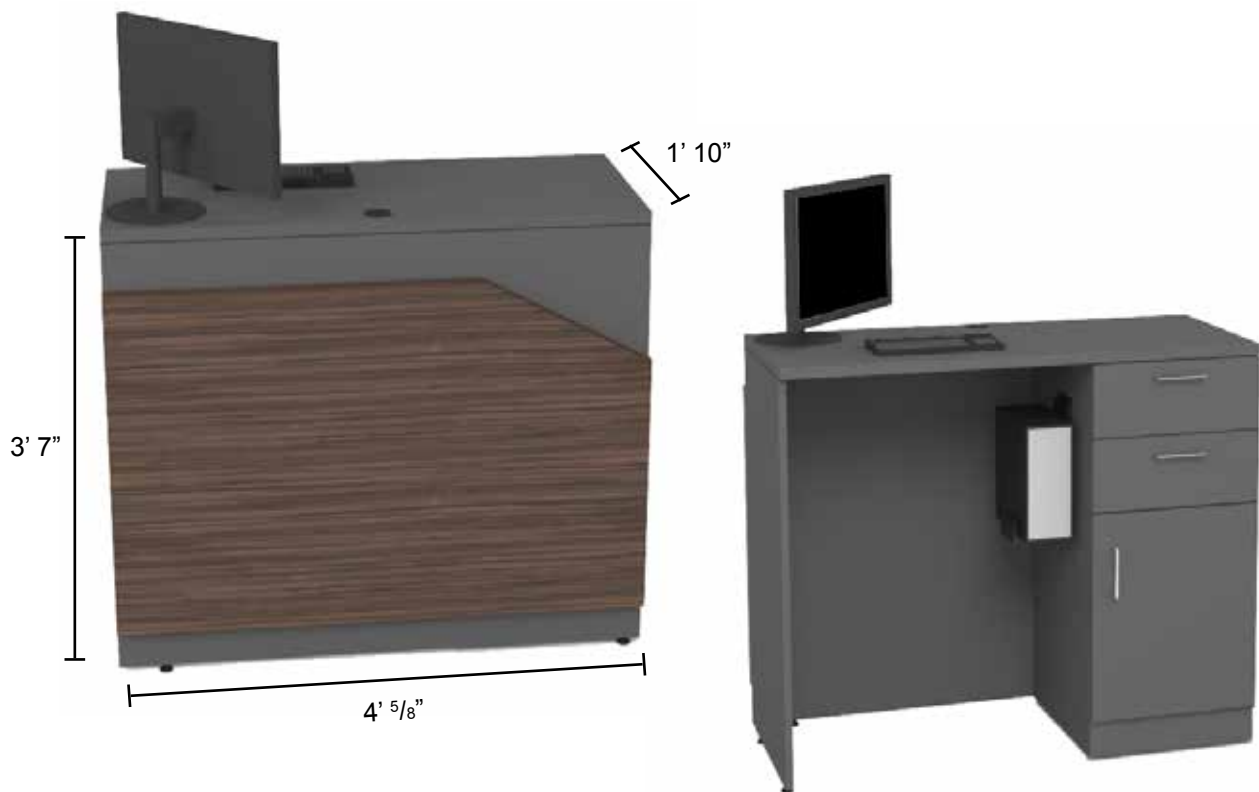

FN-1 Service Desk

Service Desk Finish in laminate with Box, Box File, Open Cabinet, and CPU Holder.

**CPU, Monitor, and Keyboard not included.*

Approx. Dim. 4' 5/8" W x 1' 10" D x 3' 7" H

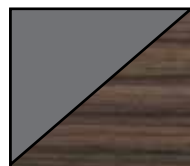

Besalt Gray w/
Milano Walnut



Option



Option NAPA Logo

Optional 1/8 inch Stainless Steel Napa Logo.

ADA Dim. 20" W x 15 3/4" T

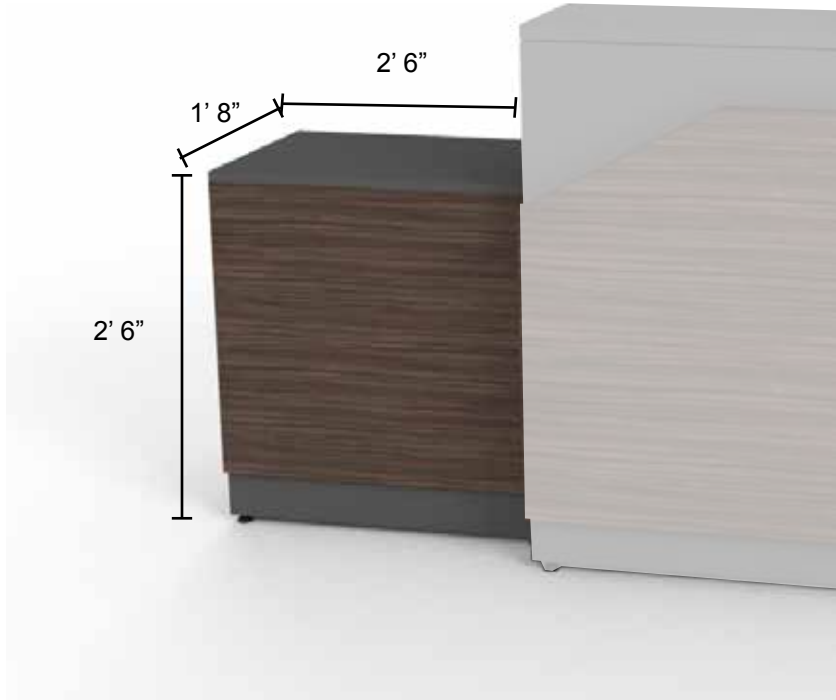

FN-1a ADA Extension - Straight

ADA Extension finished in laminate with Printer Storage/ Cabinet.

ADA Dim. 2' 6" W x 1' 8" D x 2' 6" H

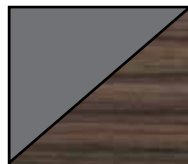

Besalt Gray w/
Milano Walnut

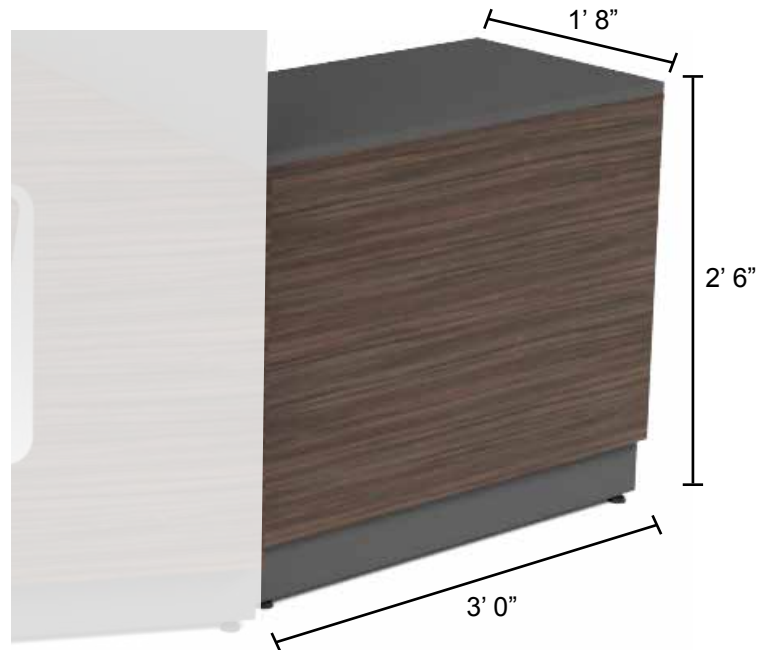

FN-1b ADA Extension - Angled

ADA Extension finished in laminate with Printer Storage/ Cabinet.

ADA Dim. 3' 0" W x 1' 8" D x 2' 6" H

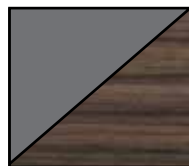

Besalt Gray w/
Milano Walnut



FN-2 Service Desk Back Counter - Large

Finished in laminate, includes (2) two door storage cabinets. **Two drawer lateral file cabinet available upon request.*

Approx. Dim. 5' 4" W x 2' 2 1/2" D x 2' 9 3/4" H



Besalt Gray w/
Milano Walnut

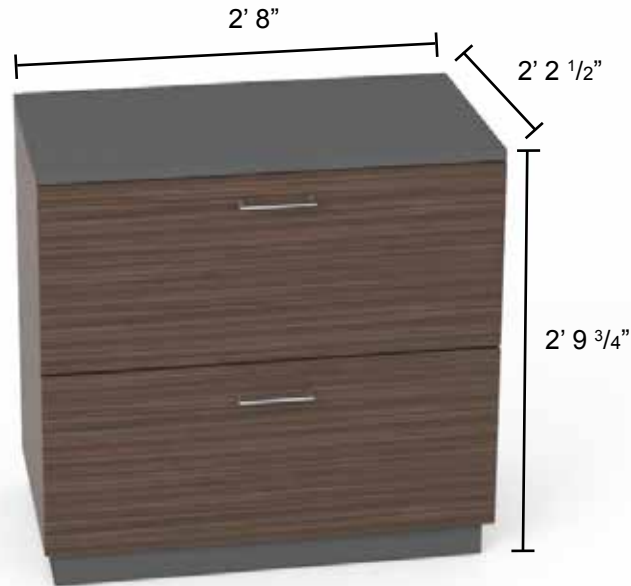

FN-2a Service Desk Back Counter - Small

Small Service Unit Back Counter- Small, finished in laminate with (1) Storage Cabinet. Two drawer lateral file cabinet available upon request.

Approx. Dim. 2' 8" W x 2' 2 1/2" D x 2' 9 3/4" H

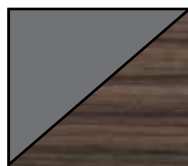

Besalt Gray w/
Milano Walnut

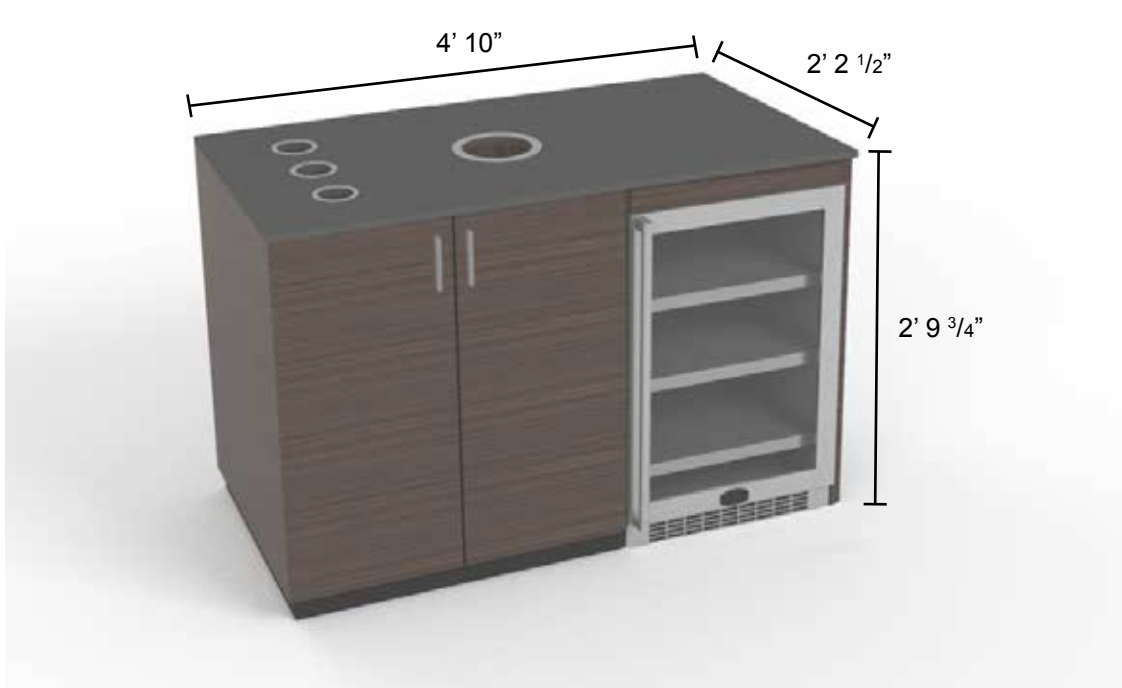

FN-3 Cafe

Finished in Laminate with (1) Storage Cabinet, Trash Ring, and Refrigerator Opening. **Shown with Optional Condiment holders and Refrigerator.*

Approx. Dim. 4' 10" W x 2' 2 1/2" D x 2' 9 3/4" H

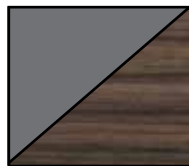

Besalt Gray w/
Milano Walnut

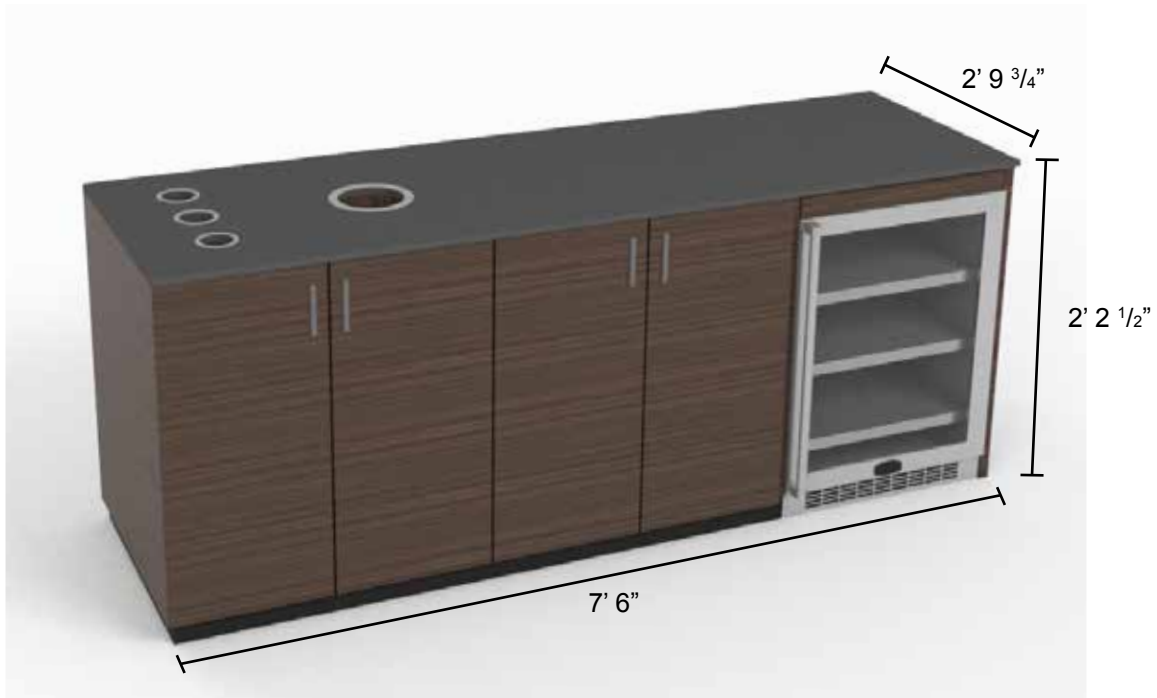

FN-3a Large Cafe

Large Café, finished in Laminate with (2) Storage Cabinets, Trash Ring, and Refrigerator Opening.

**Shown with Optional Condiment holders and Refrigerator.*

Approx. Dim. 7' 6" W x 2' 2 1/2" D x 2' 9 3/4" H

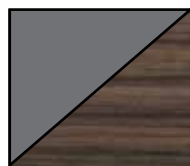

Besalt Gray w/
Milano Walnut



FN-4 Tall Cafe

Small Café, finished in Laminate with (1) Storage Cabinet and Trash Ring. **Shown with Optional Condiment holders.*

Approx. Dim. 2' 8" W x 2' 0" D x 7' 5 7/8" H

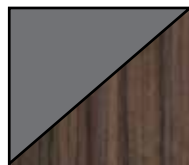

Besalt Gray w/
Milano Walnut



Option Refrigerator

Undercounter Refrigerator with glass door and metal trim for FN-3 Cafe or FN-3a Large Cafe.

Approx. Dim. 23.63" W x 23.5" D x 32.38" H

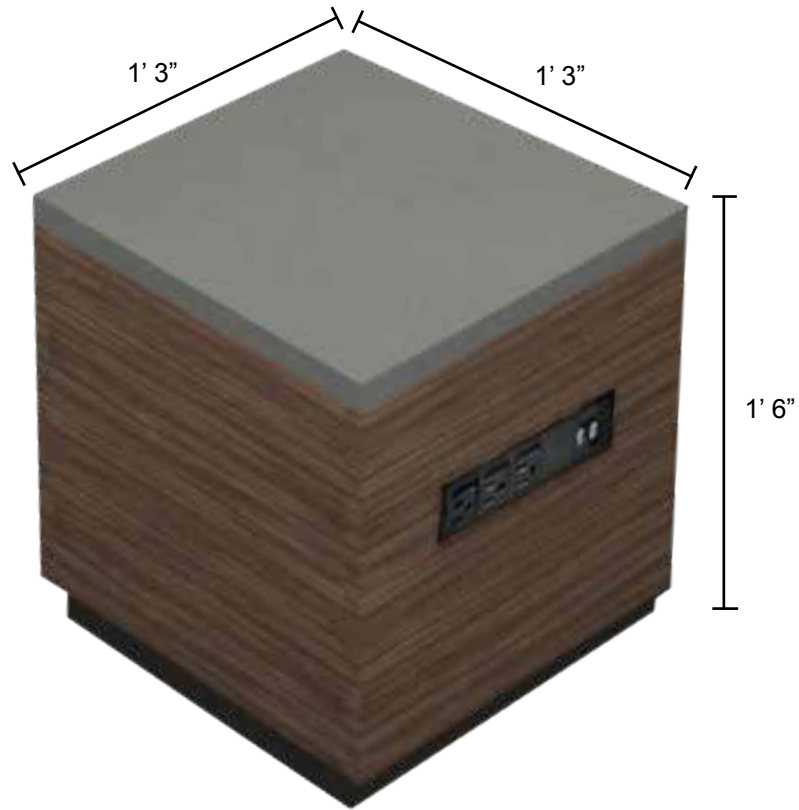

FN-5 Lounge End Table

Lounge End Table finished in Laminate with Power Grommet.

Approx. Dim. 1' 3" W x 1' 3" D x 1' 6" H

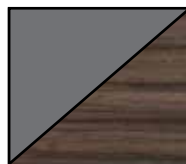

Besalt Gray w/
Milano Walnut

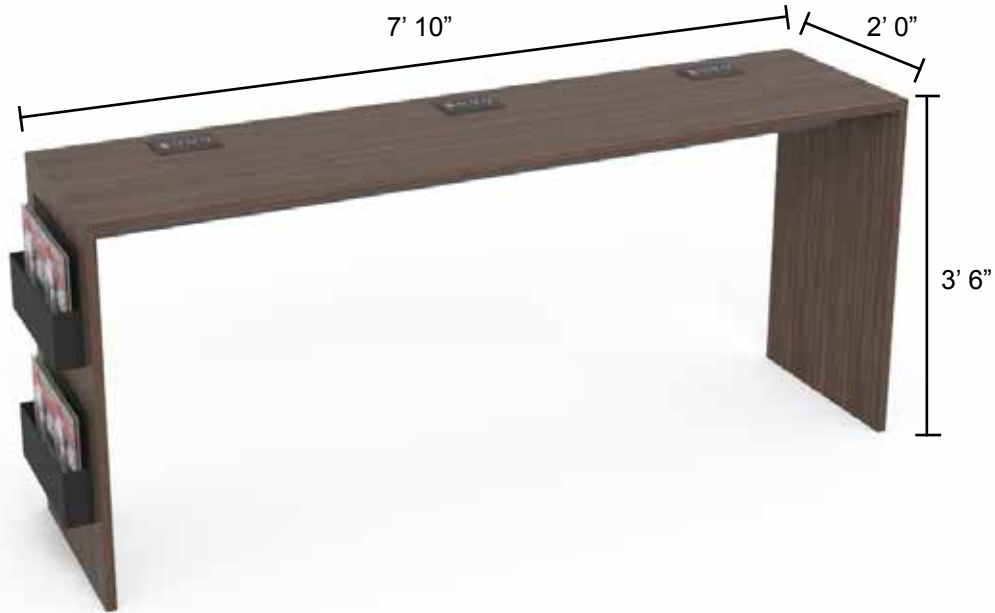

FN-6 Cafe Bar

Café Bar Freestanding- finished in Laminate with Power Grommets. **Shown with optional Magazine Holders.*

Approx. Dim. 7' 10" W x 2' 0" D x 3' 6" H

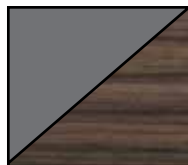

Besalt Gray w/
Milano Walnut

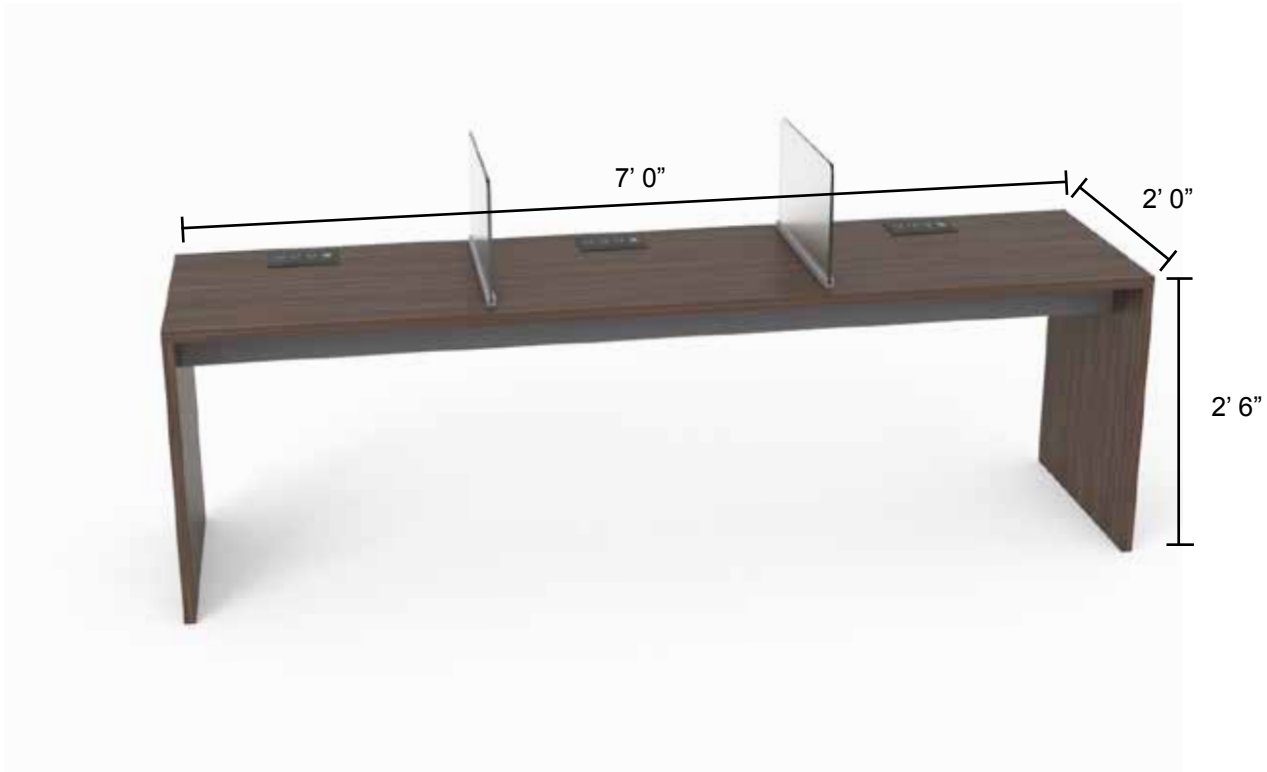

FN-7 Business Bar

Business Center- finished in Laminate with Power Grommets. **Shown with optional set of Divider Panels.*

Approx. Dim. 7' 0" W x 2' 0" D x 2' 6" H



Milano Walnut



FN-8 Cafe Table

Café Table finished in Laminate with black cast iron leg.

Approx. Dim. 30" W x 30" D x 30" H



Milano Walnut



FN-8a Tall Cafe Table

Café Table finished in Laminate with black cast iron leg.

Approx. Dim. 20" W x 20" D x 42" H



Milano Walnut

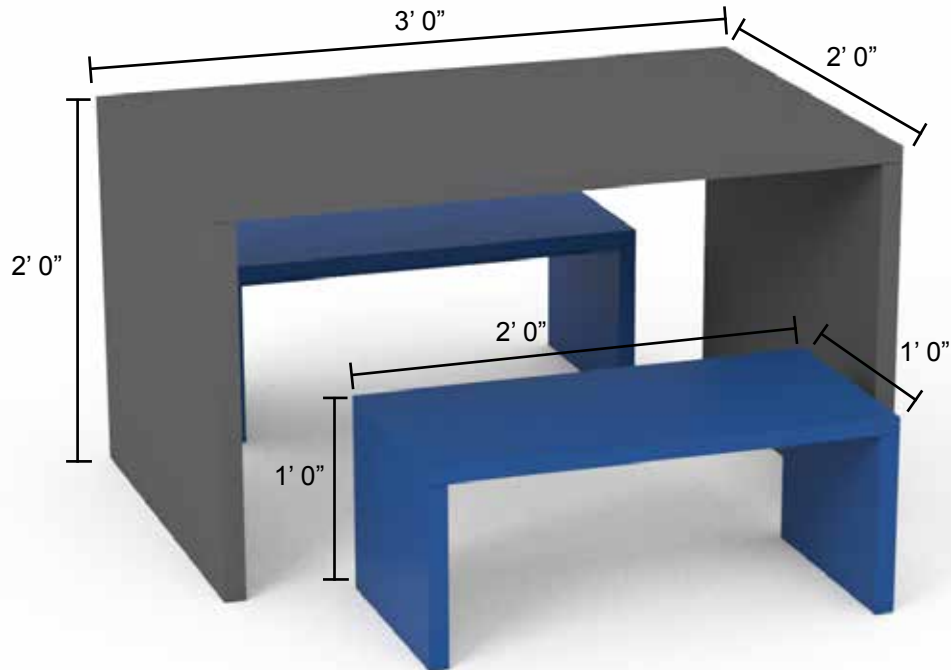

FN-9 Kids Play Table w/ (2) Stools

Kids Play Area Table with (2) Blue Laminate Stools.

Approx. Table Dim. 3' 0" W x 2' 0" D x 2' 0" H

Approx. Stool Dim. 2' 0" W x 1' 0" D x 1' 0" H

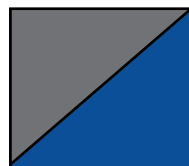

Besalt Gray w/
Gentian Blue Benches

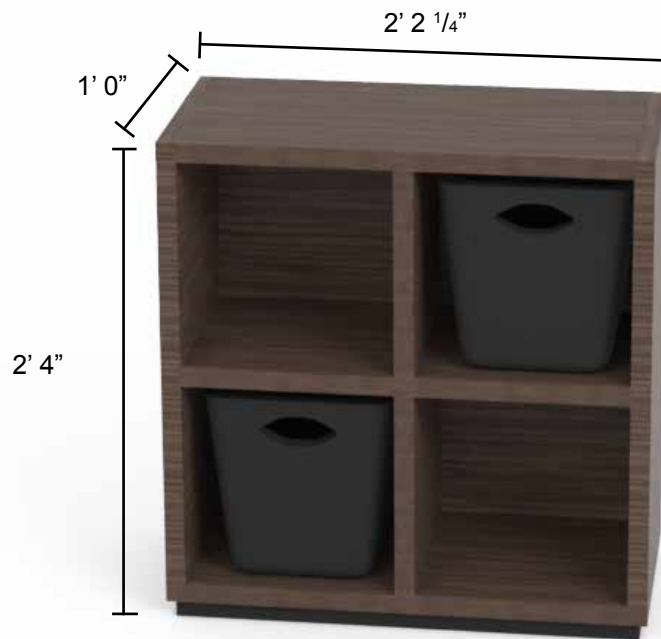

FN-9a Kids Play Area- Cubby

Kids Play Area- Cubby.

Approx. Dim. 2' 2 1/4" W x 1' 0" D x 2' 4" H



Milano Walnut



FN-10 Premium Battery / Tire Display

Battery Display- Finished in Laminate. Includes (2) Shelves, (1) Tire Bracket, and (2) Graphic Frames.
**Batteries, Wheel, and Graphics by others.*

Approx. Dim. 5' 8 1/2" W x 1' 7 7/8" D x 5' 6" H



Besalt Gray w/
Milano Walnut



FN-11 Certification Panel

Certification Panel- finished in laminate. **Certification Plaques by others.*

Approx. Dim. 7' W x 2' 5 7/8" H



Milano Walnut



**FN-12 Laminate Wainscoting w/
4\"**

Laminate Wainscoting with 4\"

Approx. Dim. 32\"

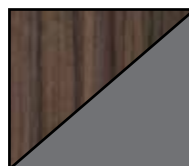

Milano Walnut
w/ Besalt Gray

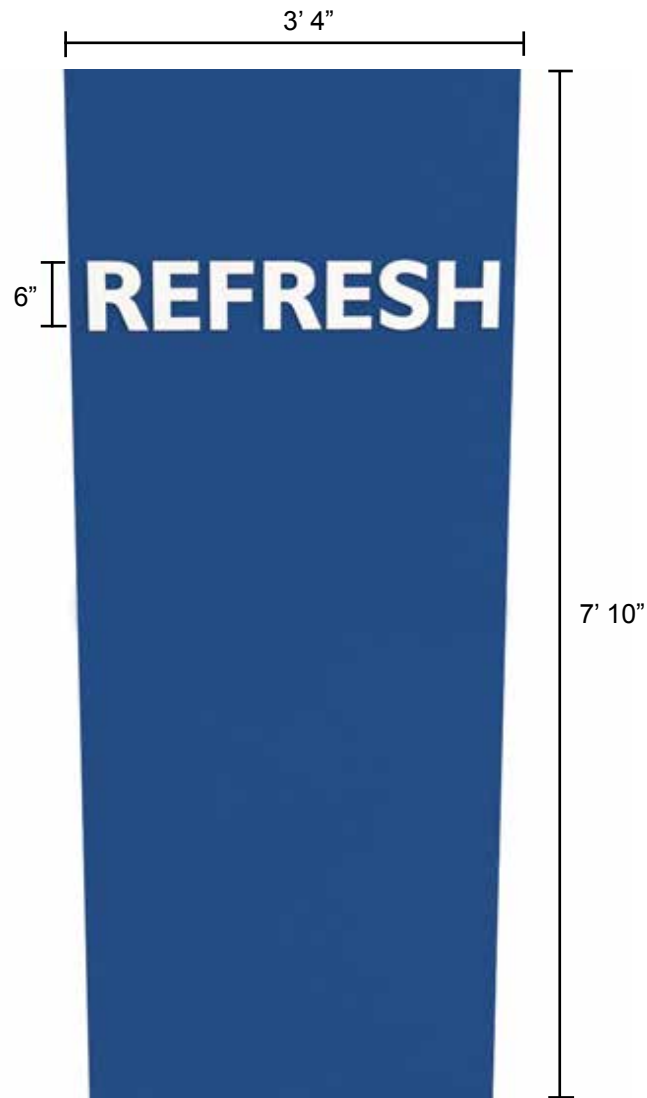

FN-13a REFRESH Wallpaneling

Blue Wallpaneling with 6" White "REFRESH" Lettering.

Approx. Dim. 3' 4" W x 1.5 x 7' 10" H

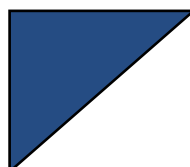

Gentian Blue
w/ White

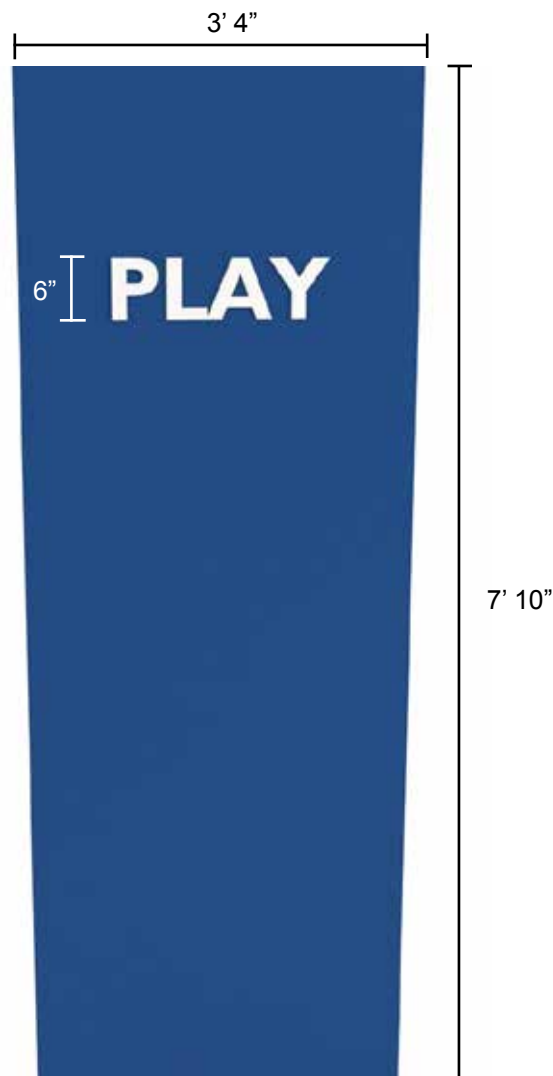

FN-13b Kids PLAY Area Wallpaneling

Blue Wallpaneling with 6" White "PLAY" Lettering.

Approx. Dim. 3' 4" W x 1.5" D x 7' 10" H

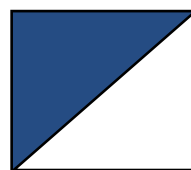

Gentian Blue
w/ White

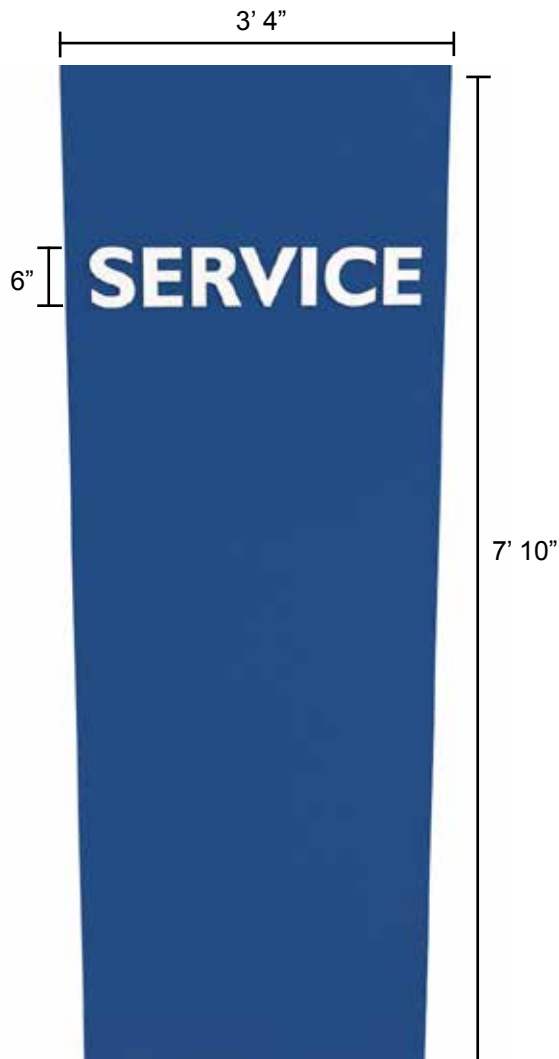

FN-13c Blue Service Display Panel

Blue Display Panel with 6" White "SERVICE" Lettering.

Approx. Dim. 3' 4" W x 1.5" D x 7' 10" H

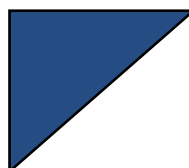

Gentian Blue
w/ White

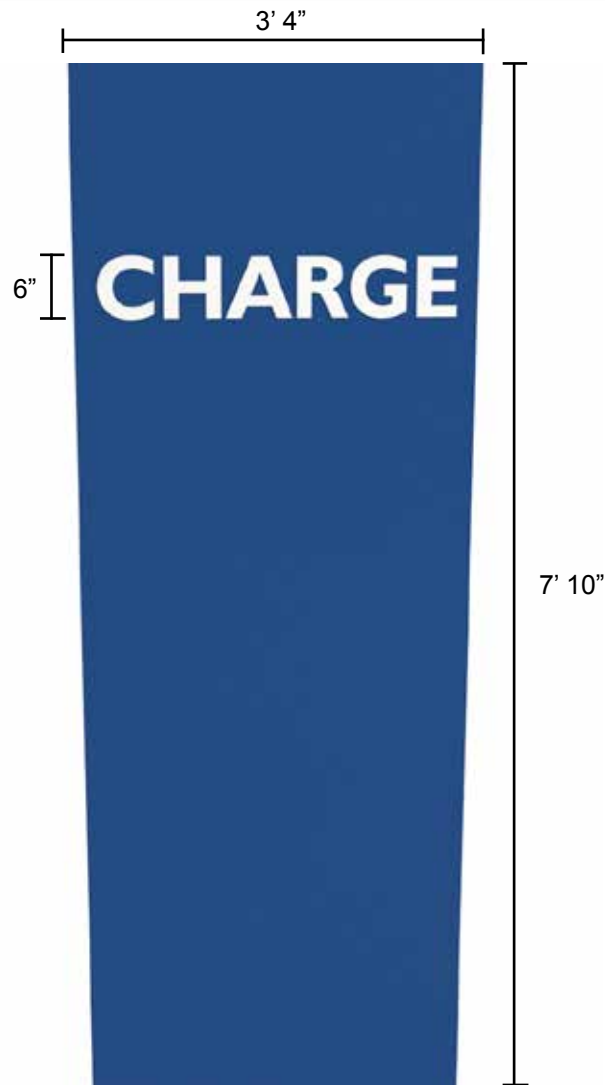

FN-13d Blue Charge Display Panel

Blue Display Panel with 6" White "CHARGE" Lettering.

Approx. Dim. 3' 4" W x 1.5" D x 7' 10" H

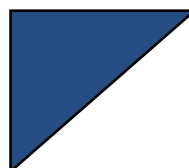

Gentian Blue
w/ White



FN-14 Windshield Wiper Display

Premium Windshield wiper display.

Approx. Dim. 1' 2" W x 2' H



Milano Walnut



FN-15 Graphic Word Wall

Wallpaper Image with destination words- per linear ft.
 Wallpaper will always be above Wainscoating. Custom
 sizing floor to ceiling available upon request.

Approx. Dim. Varies



FN-16a Fabric Warranty Graphic

Fabric Graphic- 24 Months Warranty or 36 Months Warranty.

Approx. Dim. 3' W x 3' T

24 Months

36 Months

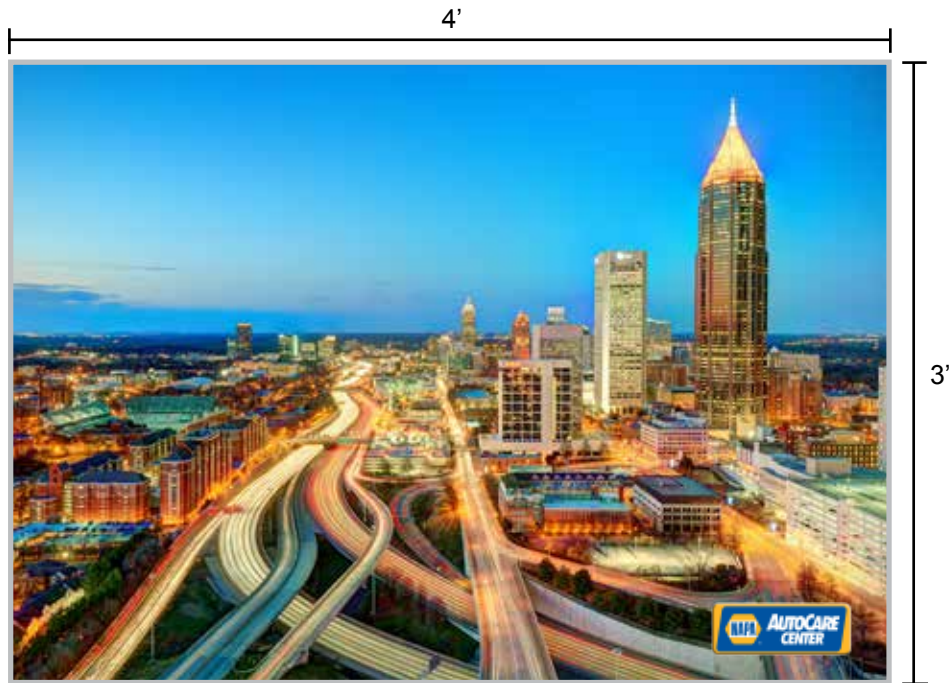

FN-16b Fabric Graphic

Premium Fabric Graphic

**Image Options - See pages 42-44.*

Approx. Dim. 4' W x 3' T







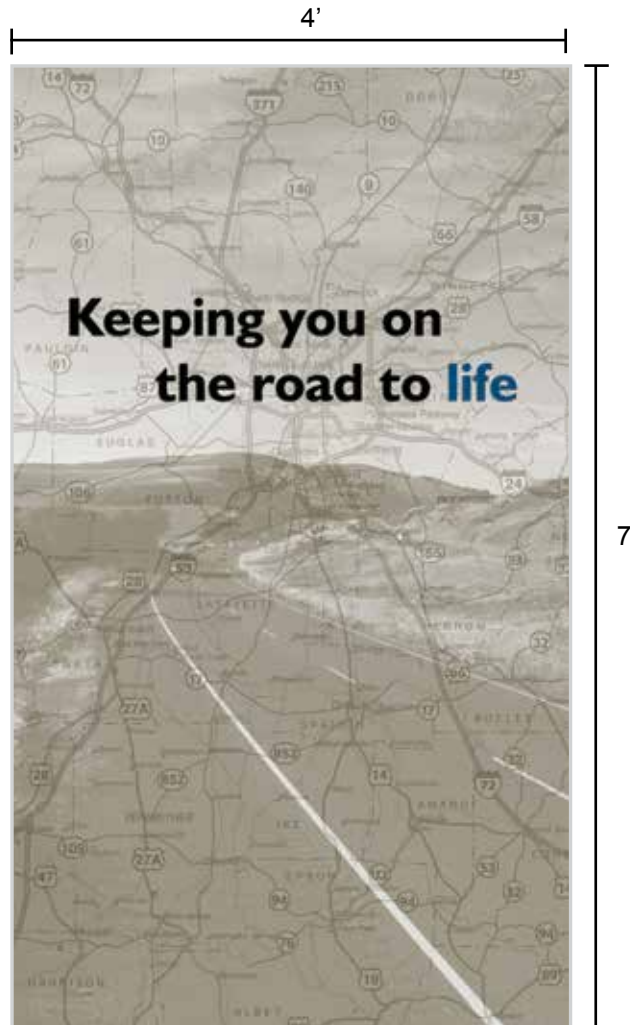

FN-16c Map Graphic

Fabric Graphic with map and “Keeping you on the road to life” slogan.

**Image Options - See page 46*

Approx. Dim. 4' W x 7' T

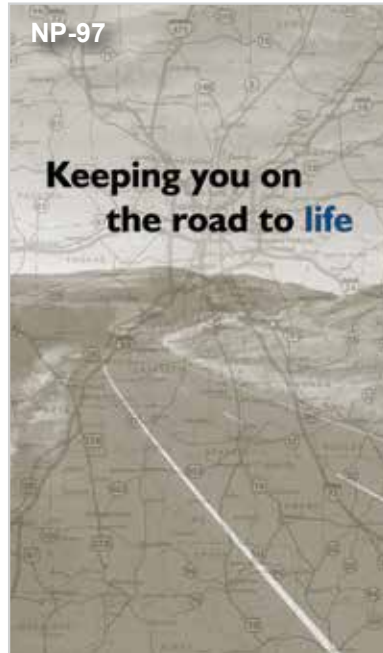

Map Graphic w/
Country Highway
background

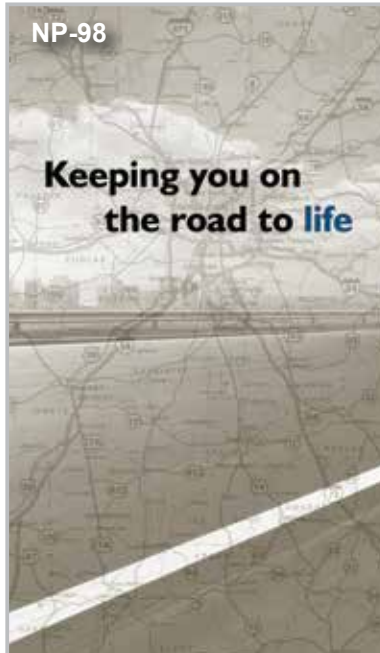

Map Graphic w/
City Highway
background

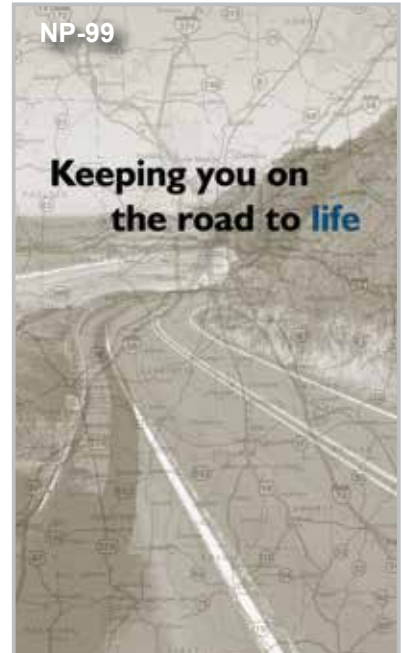

Map Graphic w/
Coastal Highway
background

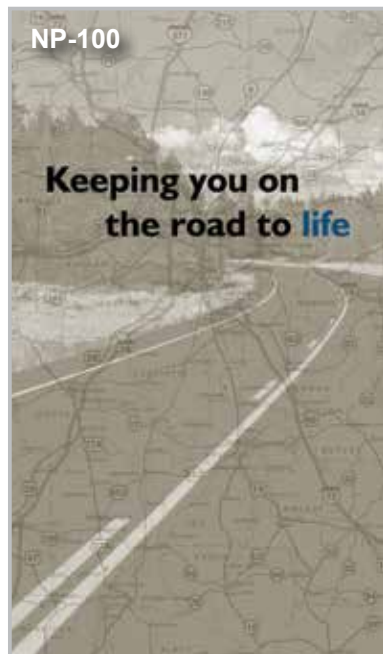

Map Graphic w/
Forest Highway
background

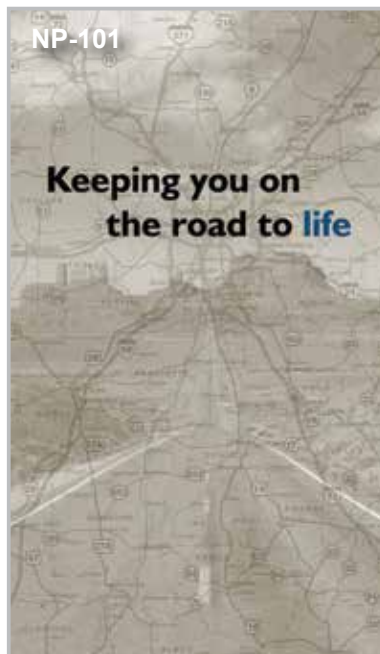

Map Graphic w/
Desert Canyon
Highway background

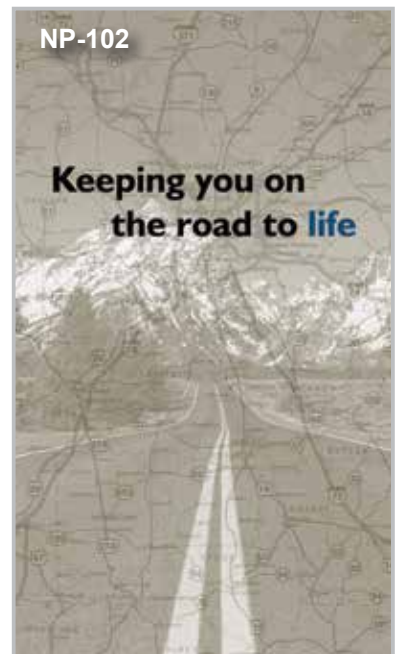

Map Graphic w/
Mountain Highway
background



FN-17



FN-17 Welcome Door Window Cling

(2) Welcome door sign window clings and (1) Business Hours cling.

Approx. Dim. 12" T x Width varies



Room Identification Sign - 8" x 4"



ADA Restroom Sign - 6.5" x 9"

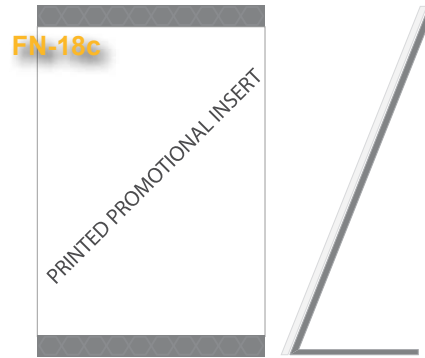

Promotional Tablestand Sign - 5.5" x 8.5"



Tablestand Sign - 6.25" x 2.75"



Flag Mount Wayfinding Sign - 10" x 6"

FN-18a-e Signage Package

Acrylic Signage with Custom back-printed design in a dark gray color palette with beige raised, tactile lettering and #2 Braille.

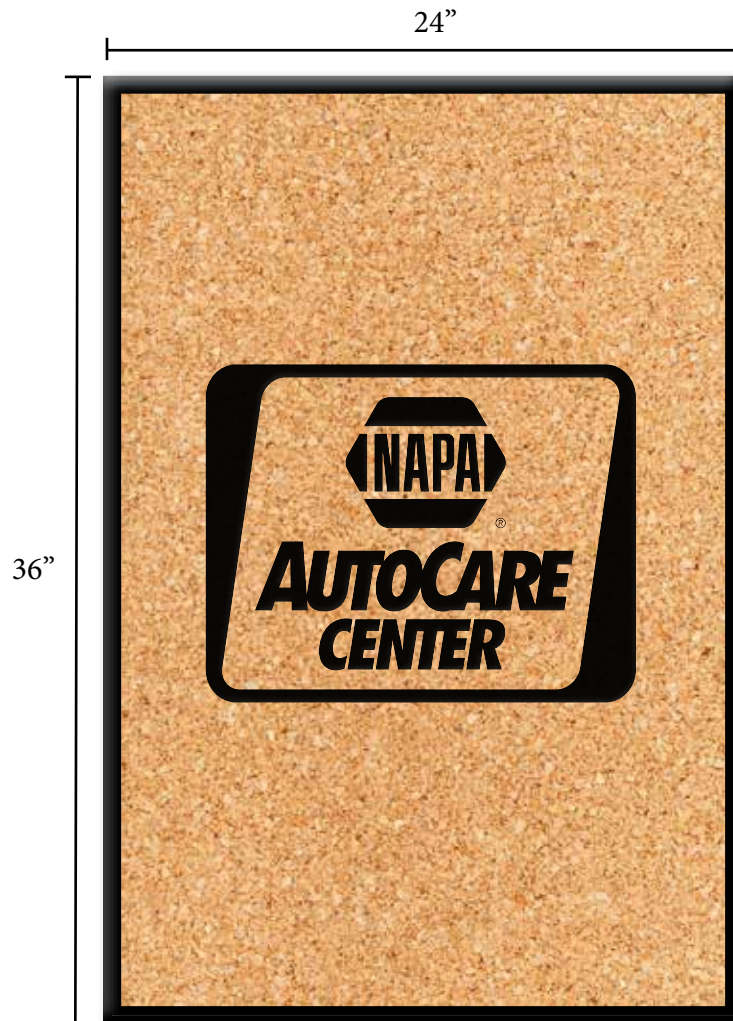

FN-19 Corkboard

Corkboard with NAPA logo design burned into the corkboard.

Approx. Dim. 24" W x 36" H



FN-20 Reception Chair, Option 1

LLR68952 Black Leather Chair with Four Leg Base
Finished in Mahogany.

Approx. Dim. 36" W x 34.5" D x 31.3" H



FN-21 Reception Chair, Option 2

LLR68953 Black Leather Chair with Writing tablet and four Leg Base finished in Mahogany.

Approx. Dim. 36" W x 34.5" D x 31.3" H



FN-22 Reception Arm-Chair

OSPWST51AB18 Black Faux Leather chair with Chrome base

Approx. Dim. 30" W x 28" D x 30" H



FN-23 Guest Chair, Option 1

LLR40201 Guest Chair with Bonded Black Leather and Solid Wood Espresso Frame

Approx. Dim. 24" W x 25.6" D x 33.3" H



FN-24 Guest Chair - Option 2

LLR84577 Black Leather Chair with Black Metal Powder-Coated Frame.

Approx. Dim. 26" W x 24.8' D x 33.5" H



FN-25 Guest Chair, Option 3

LLR2310010 Guest Chair with Mesh Back, Fabric Periwinkle Blue Seat, and Black Powder-coated Steel Frame.

Approx. Dim. 23" W x 29" D x 32" H



FN-26 Cafe Chair

LLR99864 Café Chair Natural plywood waterfall style seat with steel frame

Approx. Dim. 21" W x 20.5" D x 34" H



FN-27 Bar Stool

LLR99866 High Bar Seating, Natural plywood waterfall style seat with steel frame

Approx. Dim. 21.8" W x 20.5" D x 46" H



FN-28 High-back Chair

LLR59529 Black Leather High-back chair with height adjustable arms

Approx. Dim. 25.3" W x 23.3" D x 40.5" H



FN-29 Mesh Guest Chair

LLR86202 Black Chair with side arms, Mesh back, Fabric seat, and Cantilever base

Approx. Dim. 27" W x 27.8" D x 41" H



FN-30 Armless Guest Chair

BSXVL606VA90 Navy Blue Polyester Fabric with Black tubular steel frame

Approx. Dim. 21.5" W x 21" D x 32.8" H



FN-31 Arms Guest Chair

BSXVL616VA90 Guest Chair with arms, Navy Blue Polyester Fabric with Black tubular steel frame

Approx. Dim. 23.3" W x 21" D x 32.8" H

FLOORS & PAINT

Floors & Paint

We have provided you with our designer color palette for the floors, doors, and walls that match and compliment the furniture, wallcoverings, graphics, and fixtures as laid out in this catalog.



**Flooring -
Hickory**



**Wall Paint -
Simply Beige**



**Trim Paint -
Grizzle Gray**



**Door Paint -
Gray Screen**

**(See next page for specific paint names and numbers for the corresponding walls, doors, and trim and where to purchase them.)*

“Attitude and willingness to accept and embrace change contribute to the success of automotive repair shops.”

– Mitch Schneider, Automotive Management Instructor



Where to Purchase



Flooring - Hickory

Lowes - Shaw Matrix Franklin Floating Hickory Luxury Vinyl Planks
Item #: 516563 | Model #: LX90100705 (14-Piece 5.9-in x 48-in, covers
27.58 sq. ft. per carton)

Home Depot - Pergo XP Coffee Handscraped Hickory- Model#
LF000739; Store SKU# 1000030798 (47¼"L x 5¼"W, covers 13.74 sq.
ft. per carton)

Menards - Shaw Citadel Chippewa Hickory- SKU# 725-6542 (36.84"L
x 5.91"W covers 18.14 sq. ft. per carton)

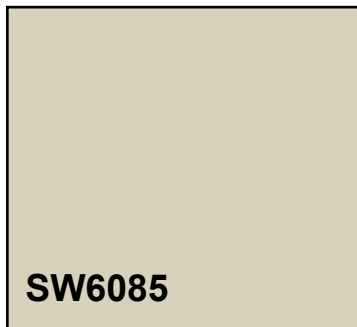

Wall Paint - SW6085 - Simply Beige

(One gallon covers approximately 400 sq. ft. of wall space)

Lowes - SW6085 Sherwin Williams Simply Beige Emerald Satin

Home Depot - SW6085 Behr Ultra (Base 7750)

Menards - SW6085 Dutch Boy, or - SW6085 Pittsburgh,
or -SW6085 Conco

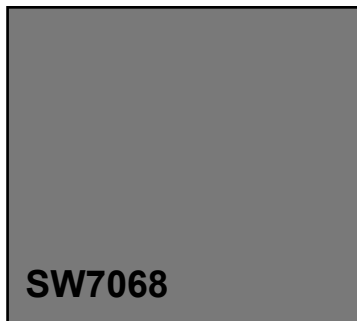

Trim Paint - SW7068 - Grizzle Gray

(One gallon covers approximately 400 sq. ft. of wall space)

Lowes - SW7068 Sherwin Williams Grizzle Gray Latex Semi-Gloss.

Home Depot - SW7068 Behr Ultra (Base 3753)

Menards - SW7068 Dutch Boy, or - SW7068 Pittsburgh,
or -SW7068 Conco

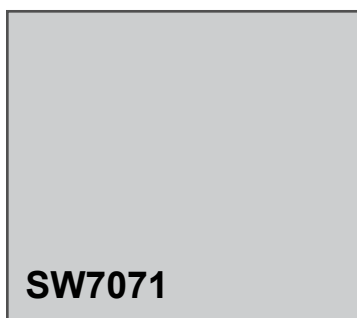

Door Paint - SW7071 - Gray Screen

(One gallon covers approximately 400 sq. ft. of wall space)

Lowes - SW7071 Sherwin Williams Gray Screen Semi-Gloss Extra.

Home Depot - SW7071 Behr Ultra (Base 3750)

Menards - SW7071 Dutch Boy, or - SW7071 Pittsburgh,
or - SW7071 Conco



Taking It Further

Improving your service facility's exterior helped your building stand out — now keep their attention with a quality, customer-friendly interior space.

PROimage Interior Checklist

- PROimage* Interior Submission Form with contact information
- PROimage* Interior Questionnaire
- Hand drawing of location with measurements and details (include in hand drawing the desired locations of service counter(s) and seating)
- Pictures of location's current interior (suggested but not required)

You will receive a 2D and 3D drawing within 3 to 5 business days of submittal to review the location of items included. You are asked to reply with any changes or suggestions. Pricing for any item can be requested at support@napaproimage.com.



Questions? Please call The *PROimage* Resource Center at 1.855.888.6272.

Submission Form

Once completed send your drawing and this submission form to support@napaproimage.com. This form will be used to contact those identified with questions pertaining to the rendering process. Return of the Interior 2D and 3D drawing will be submitted to the e-mail addresses listed below.

NAPA AutoCare Information

Shop Name _____

Location ID (CM#) _____ City _____ ST _____

Owner Name _____

Contact Information (in order of preference)

Phone Number 1 _____ Name _____

Phone Number 2 _____ Name _____

Phone Number 3 _____ Name _____

Send Drawings to:

Email 1 _____

Email 2 _____

Email 3 _____

Questions? Please call The PROimage Resource Center at 1.855.888.6272.

PROimage Interior Questionnaire

What areas of your shop would you like included in the quote and in what priority?
 (ie. Waiting area, office, breakroom, etc) _____

What are the current challenges you have in these areas for traffic flow or seating availability?

What is the average number of customers waiting at any given time in your waiting area?

- 1 to 4
 4 to 8
 8 to 12
 12+ please specify

How many service desk do you need?

- 1
 2
 3
 4
 4+ please specify

Do the service writers need a stool for sitting?

- Yes No

Do you need a receptionist station in the waiting area?

- Yes No

Do you typically have children waiting with their parents?

- Yes No

Do you want a coffee service area for your customers?

- Yes No

What is your estimated date to make a decision and place an order? _____

What is your desired completion date? _____

Do you have any scheduled events that dictates the completion date? Yes No

Please provide any additional information that you feel would be helpful.

Field Measuring Guide

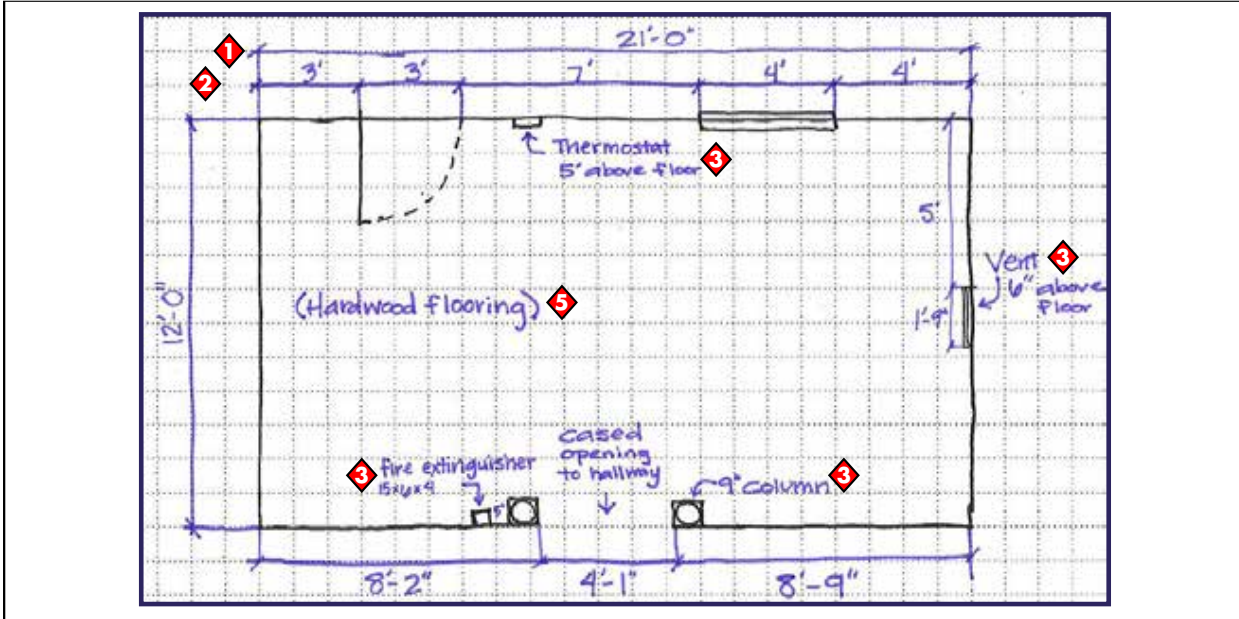

KEY INFORMATION

- ◆ **1** Wall to wall length:
 - Measure above the baseboard
 - Measure from corner to corner
- ◆ **2** All door, window, and openings:
 - Include molding with wall measurement
 - Measure wall to door or window opening
- ◆ **3** Note any obstructions and services:
 - Columns (and their size), vents, fire extinguishers, thermostats, phone, power, data etc.
- ◆ **4** Height of windows:
 - Measure from floor to bottom of molding
- ◆ **5** Note flooring type:
 - This helps us know what kind of chair castors to specify
- ◆ Note any built-in fixtures:
 - Bookshelves, cabinetry, sink, fireplace, etc.

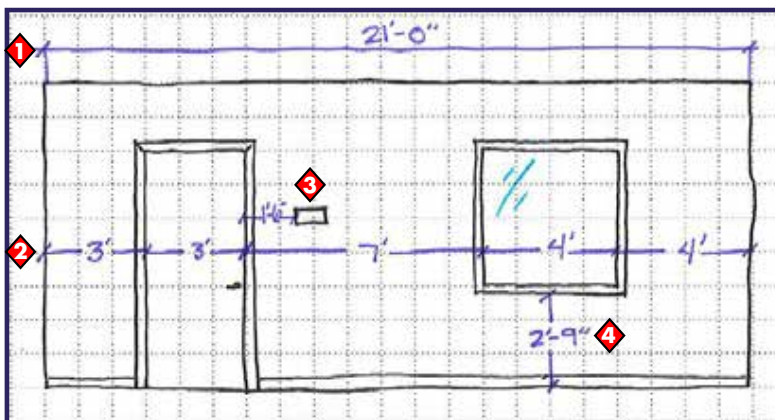

TIPS

- Label everything
- Do not make assumptions on any measurements
- Note the door swing
- Note the ceiling height
- Every inch counts
- Use graph paper

Field Measuring Guide

Shop Name _____

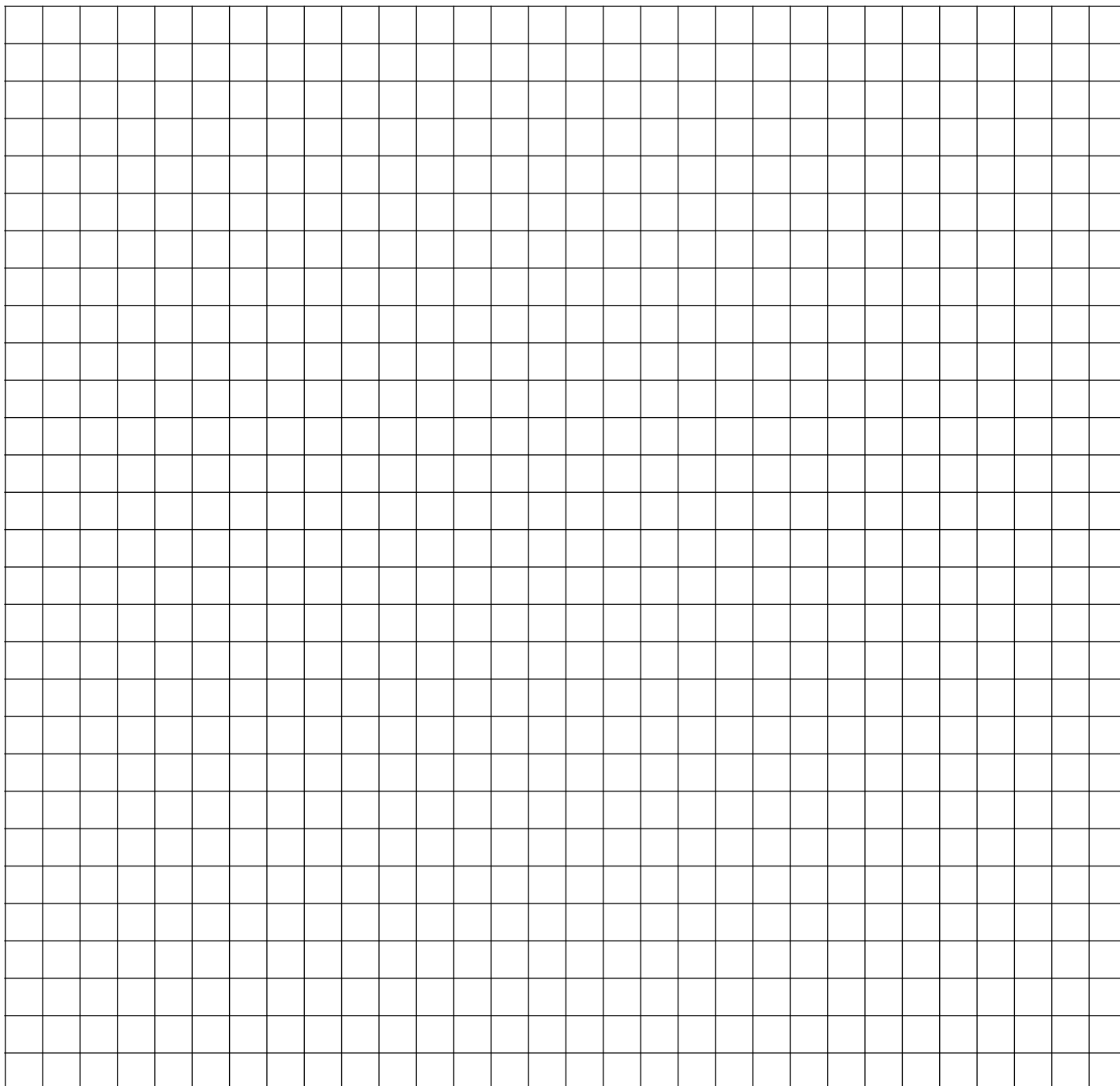

 1 square = 1 foot

PROimage Resource Center: 1.855.888.6272.

RESTROOM ETIQUETTE

Restroom Etiquette -

Believe it or not restrooms are one of the most important areas of any business. They provide your customers with insight on how much you pay attention to details.

If a facilities' restrooms are clean and well maintained, customers take comfort in knowing that the same quality of care and service will be given to them. On the other hand, if a restroom is dirty and questionable the customer tends to harbor those same thoughts towards the service and care they are receiving.

One of the best business investments you can make, is in your restrooms. Your customers will thank you, and it very well may be the deciding factor in choosing you over your competitors.

- Dirty restrooms provide your customers insight into your store or company on how much you pay attention to details.

